

CLASS 150

AWWA C504 Double Flanged Butterfly Valve

Fig. 2102



Valve Standard :
Comply with AWWA C504

Pressure Temperature Ratings

Working pressure	150psi
Testing Pressure	Shell:300psi Seal:165psi
Working Temperature	-4°F to 230°F EPDM Seat 14°F to 176°F NBR Seat
Suitable Media	Water, Oil & Gas

Material Specification

Part	Material	ASTM
Body	Ductile Iron	A536 Gr. 65-45-12
Disc	Ductile Iron	A536 Gr. 65-45-12
	Bronze	B148 C95400
	Stainless Steel	A351 CF-8
	Stainless steel	A351 CF-8M
Shaft	Stainless Steel	A276 S 410 00
	Stainless Steel	A276 S 410 00
Seat Ring	EPDM / NBR	
O-Ring	EPDM / NBR	
Bushing	Bronze	B62 C83600

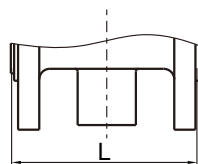
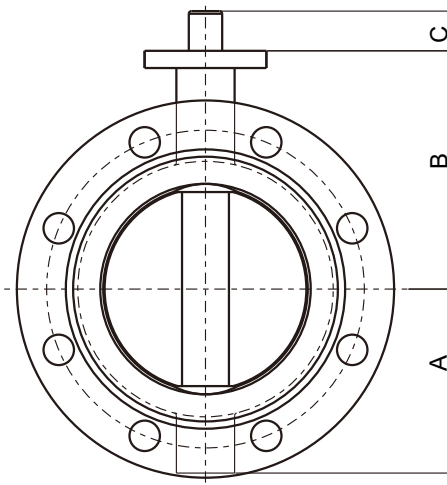

Dimensions

DN	mm	80	100	150	200	250	300	350	400	450
	inch	3	4	6	8	10	12	14	16	18
A		3.82	4.69	6.14	7.36	8.2	9.86	11.42	12.63	13.52
B		5.16	5.91	7.09	8.27	9.67	10.83	12.91	14.8	16.01
C		1.18	1.18	1.26	1.57	1.97	1.97	1.97	2.76	3.35
L		5	5	5	6	8	8	8	8	8

DN	mm	500	600	750	900	1050	1150	1200	1350	1500
	inch	20	24	30	36	42	46	48	54	60
A		16.08	18.78	20.33	24.21	28.74	41.2	39.4	45.7	50.1
B		17.64	20.39	24.02	27.24	34.06	41.8	34.8	39.2	41.8
C		3.74	4.33	3.74	5	5.12	5.91	5.91	7.87	7.87
L		8	8	12	12	12	15	15	15	15