

Fig. 5121



Valve Standard :
Comply with AWWAC508

Pressure Temperature Ratings

Working pressure(Bar)	250PSI
Testing Pressure(Bar)	Shell:375PSI Seal:275PSI
Working Temperature(°C)	-10°C to +120°C
Suitable Media	Water, Oil & Gas

Material Specification

Part	Material	Material Code
Body	Ductile Iron	A536 Gr.65-45-12
Disc	Ductile Iron + EPDM / NBR	A536 Gr.65-45-12
Gasket	EPDM / NBR	EN-JS 1050+EPDM
Plug	Ductile Iron	A536 Gr.65-45-12
Cover	Ductile Iron	A536 Gr.65-45-12

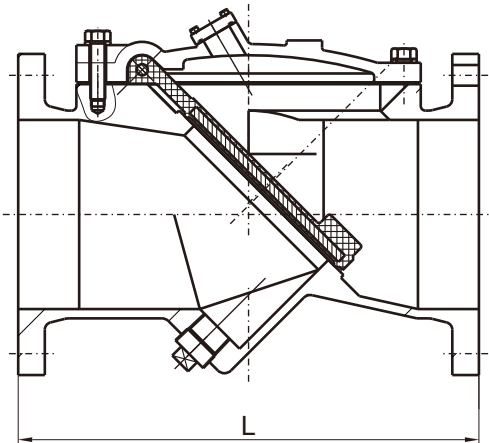

Dimensions

DN	mm	50	65	80	100	150	200	250	300
	inch	2"	2-1/2"	3"	4"	6"	8"	10"	12"
L		203	216	241	292	356	495	622	699