

EXPANSION JOINT

Stainless Steel Expansion Joint Complete With Shipping Rods

Fig.GF900

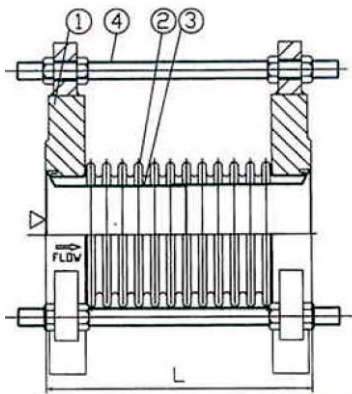

Application

Water, Steam, Turbines, Gas, Fuel Oil, Air, Etc.

Max. Working Temperature

220°C

Max. Working Pressure

16 and 25 kgf/cm²

Construction

No.	Parts	Materials
1	Flange	Carbon Steel
2	Bellows	Stainless Steel
3	Sleeve	Stainless Steel
4	Shipping Rod	Carbon Steel

Specification

Nominal Diameter		overall length	Axial Movement	Working Pressure
mm	inch	mm	mm	Kgf/cm ²
20	3/4	120	±15	16/25
25	1	120	±15	16/25
32	1-1/4	120	±15	16/25
40	1-1/2	150	±15	16/25
50	2	150	±15	16/25
65	2-1/2	150	±20	16/25
80	3	150	±20	16/25
100	4	200	±20	16/25
125	5	200	±20	16/25
150	6	200	±20	16/25
200	8	250	±20	16/25
250	10	250	±20	16/25
300	12	250	±20	16/25
350	14	250	±20	16/25
400	16	300	±20	16/25
450	18	300	±20	16/25
500	20	300	±20	16/25
600	24	300	±20	16/25

Remarks:

Others flange standard, larger size, various length & axial movement available on request.