



## Medium Velocity Water Spray Nozzle Model: A, AS, B, BS & E

### General Description

Medium Velocity Water Spray Nozzles are open type (nonautomatic) nozzles, designed for directional spray application in fixed fire protection system.

Medium velocity water spray nozzle has an external deflector, which discharges water in a directional cone shaped pattern of small droplet size. The water is uniformly distributed over the surface to be protected.

The Nozzles are effectively designed to apply water to exposed vertical, horizontal, curved and irregular shaped surfaces to allow cooling to prevent excessive absorption of heat from external fire and avoid structural damage or spread of fire. In some application nozzles may be installed to control or extinguish the fire depending on water design density as per applicable codes. The nozzle is used in deluge water spray system for special hazard fire protection application.

As the design and intent of specific water spray system may vary considerably, MV nozzle is made available in several combinations of orifice sizes and spray angles.

The minimum desirable pressure to achieve a reasonable spray pattern is 1.4 Kg./Sq.cm. The water distribution pattern as shown in the graph in following pages is at an average pressure of 2.0 Kg/Sq.cm. The change in pressure between 1.4 to 3.5 Kg./sq.cm. does not affect considerable change in spray angle.

The spray pattern shown is with indoor application. System designer must consider wind velocity while designing the system for outdoor application. Field obstruction if any affecting the spray pattern of the nozzle must also be considered. The nozzle may be oriented to any position as deemed necessary to cover the hazard.

The Blow-off plugs can be used to prevent the depositing of foreign materials in the water way of the nozzles, which could interfere with discharge of the spray nozzle. Blow-off plugs are optional and are FM Approved. Blow-off Plugs have identification mark with respect to K factor. Blow off plug for nozzle having K-factor 22 will have identification mark of 22. Minimum operating pressure for nozzle having Blow-off plug is 1.4 Kg./Sq.cm (20 PSI).

The main pipeline strainer as per NFPA-15 is required for system utilizing nozzle orifice diameter less than 9.5mm (3/8 inch), i.e.MV Nozzle having K-factor 51 and less, and also for the system water likely to contain obstructive materials



### Technical Details

Model	MV-A, MV-AS Brass MV-B & MV-BS Stainless Steel MV-E Aluminium Bronze																						
Type	MV-A, MV-B & MV-E (without strainer) MV-AS & MV-BS (with strainer)																						
Maximum Working Pressure	12 bar (175 psi)																						
End Connection	½" BSPT (½" NPT optional)																						
Included Water Spray Angle For Each K-Factor	140°, 120°, 110°, 100°, 90°, 80° & 65°																						
K-Factor	<table border="1"> <thead> <tr> <th>MV-A/MV-B &amp; MV-E Metric(US)</th> <th>MV-AS/MV-BS Metric(US)</th> </tr> </thead> <tbody> <tr> <td>K-18 (1.26)</td> <td>K-18 (1.26)</td> </tr> <tr> <td>K-22 (1.54)</td> <td>K-22 (1.54)</td> </tr> <tr> <td>K-30 (2.10)</td> <td>K-30 (2.10)</td> </tr> <tr> <td>K-35 (2.45)</td> <td>K-35 (2.45)</td> </tr> <tr> <td>K-41 (2.87)</td> <td>K-41 (2.87)</td> </tr> <tr> <td>K-51 (3.57)</td> <td></td> </tr> <tr> <td>K-64 (4.48)</td> <td></td> </tr> <tr> <td>K-79 (5.53)</td> <td></td> </tr> <tr> <td>K-91 (6.37)</td> <td></td> </tr> <tr> <td>K-102 (7.14)</td> <td></td> </tr> </tbody> </table>	MV-A/MV-B & MV-E Metric(US)	MV-AS/MV-BS Metric(US)	K-18 (1.26)	K-18 (1.26)	K-22 (1.54)	K-22 (1.54)	K-30 (2.10)	K-30 (2.10)	K-35 (2.45)	K-35 (2.45)	K-41 (2.87)	K-41 (2.87)	K-51 (3.57)		K-64 (4.48)		K-79 (5.53)		K-91 (6.37)		K-102 (7.14)	
MV-A/MV-B & MV-E Metric(US)	MV-AS/MV-BS Metric(US)																						
K-18 (1.26)	K-18 (1.26)																						
K-22 (1.54)	K-22 (1.54)																						
K-30 (2.10)	K-30 (2.10)																						
K-35 (2.45)	K-35 (2.45)																						
K-41 (2.87)	K-41 (2.87)																						
K-51 (3.57)																							
K-64 (4.48)																							
K-79 (5.53)																							
K-91 (6.37)																							
K-102 (7.14)																							
Weight	110 g. (approximately)																						
Finish	MV-A & MV-AS Natural Brass finish, Chrome plated Nickel, Electroless Nickel plated, Epoxy powder coated. MV-B, MV-BS & MV-E Natural finish																						
Approvals	Nozzle - UL Listed, FM Approved Blow-off Plug - FM Approved																						
Ordering Information	Specify K-Factor, spray angle, finish, model and end connection																						

# Medium Velocity Water Spray Nozzle

## Model: A, AS, B, BS & E

### Installation & Maintenance

The spray nozzle must be handled with due care. For best results, the storage as well as any further shipment be made in original packing only.

Nozzle which is visibly damaged should not be installed. Use Teflon tape or soft thread sealant on male thread of the nozzle.

The nozzles must be hand tightened into the fitting. After hand tightening use Nozzle Wrench- NW-M for wrench tightening in to nozzle fittings. Excessive tightening torque may result into serious damage to nozzle arms and the deflector, which may affect spray pattern of the nozzle and its performance.

It is recommended that water spray system be inspected regularly by authorised technical personnel.

The nozzle must be checked for atmospheric effects, external and internal obstruction, blockage if any. The system must be operated with optimum water flow at least twice in a year or as per the provisions of NFPA /TAC or local authority having jurisdiction.

The owner is solely responsible for maintaining the water spray system and the components there in so that it performs properly when required.

Model MV-A, MV-B & MV-E

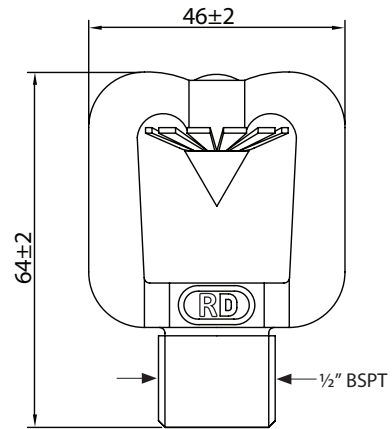

Model MV-AS & MV-BS

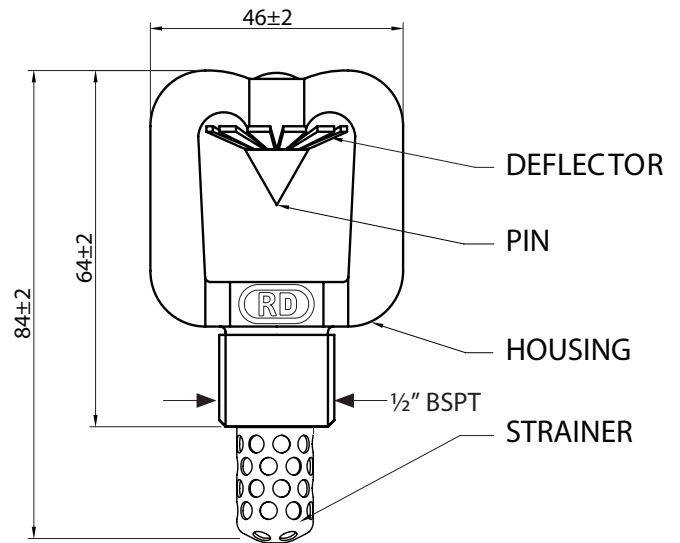

Nozzle with Blow-off Plug

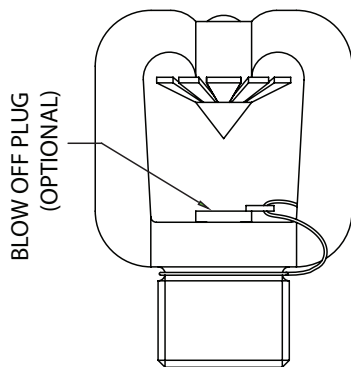

Table - I : Material Of Construction

Component	Model MV-A & MV-AS	Model MV-B & MV-BS	Model MV-E
Housing	Brass, IS:291 GR.-1 (Equivalent to ASTM B21)	A351-CF8M	Aluminium Bronze IS:305-AB1 (Equivalent to ASTM B148)
Pin	Brass IS:291. GR. -1 (Equivalent to ASTM B21)	ASTM-A479 GR 31803	Ph.Bronze IS:7811 (Equivalent to ASTM B139)
Deflector	Brass IS:2768 (Equivalent to ASTM B36)	ASTM A240 GR 2205	Ph.Bronze IS:7814- GR-II (Equivalent to ASTM B103)
Strainer	Copper (For MV-AS)	Stainless Steel 316 (For MV-BS)	-
Blow-off Cap	Elastomer	Elastomer	Elastomer



# Medium Velocity Water Spray Nozzle Model: A, AS, B, BS & E

## Discharge Characteristics

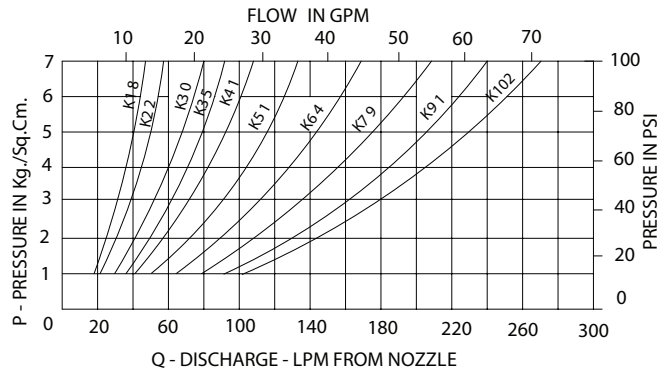

$Q = K \sqrt{P}$  where P is supply pressure in Kg/sq.cm., K= nozzle constant (K-factor) in metric  
US K factor = Metric K factor  $MK \div 14.2745$

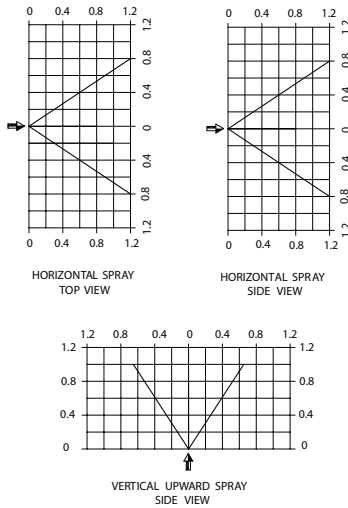

SPRAY ANGLE 65°

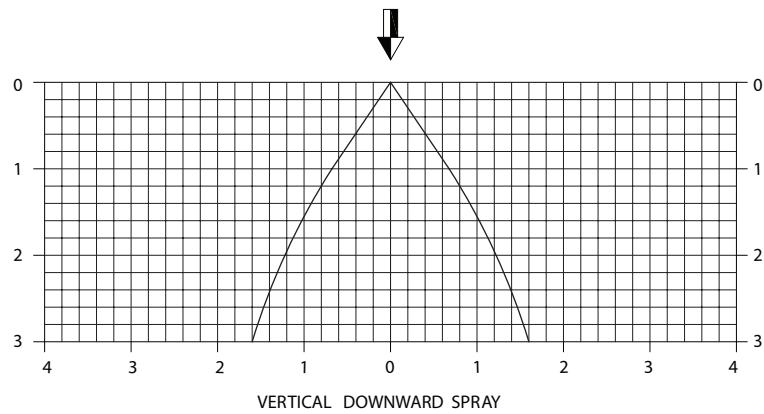

SPRAY ANGLE 80°

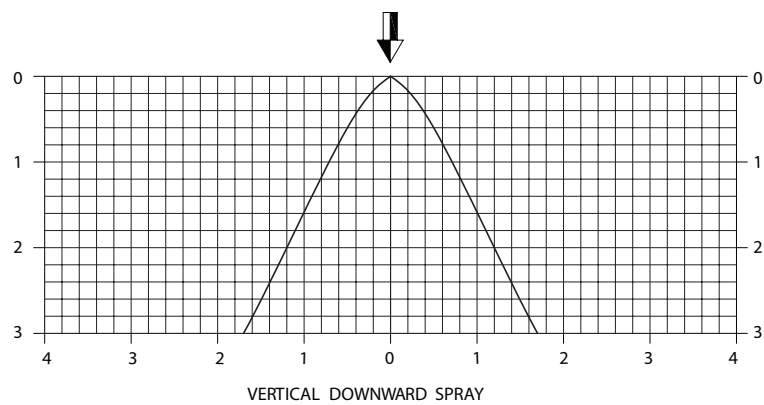
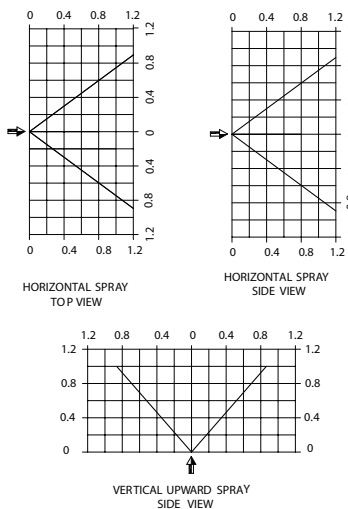

All Dimensions Are In Meters



# Medium Velocity Water Spray Nozzle

## Model: A, AS, B, BS & E

### SPRAY ANGLE 90°

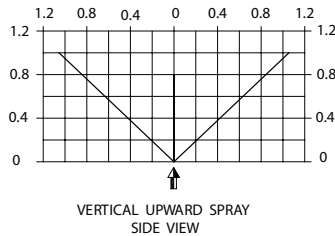
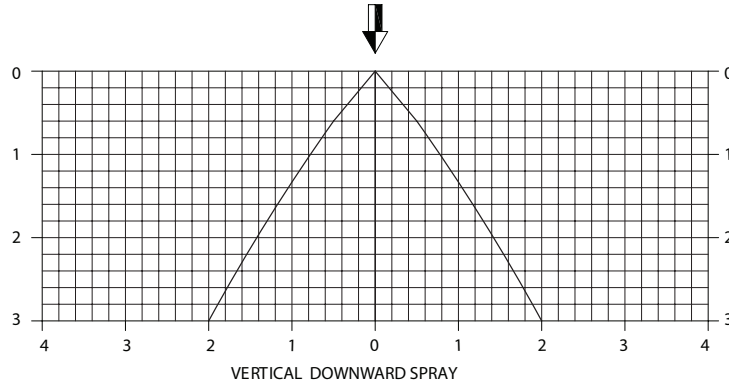
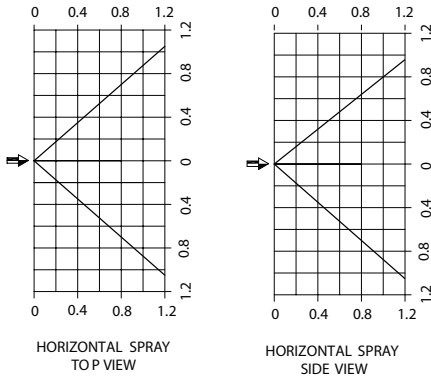

### SPRAY ANGLE 100°

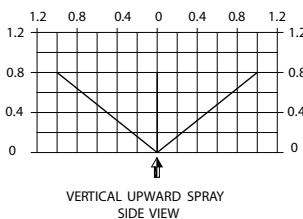
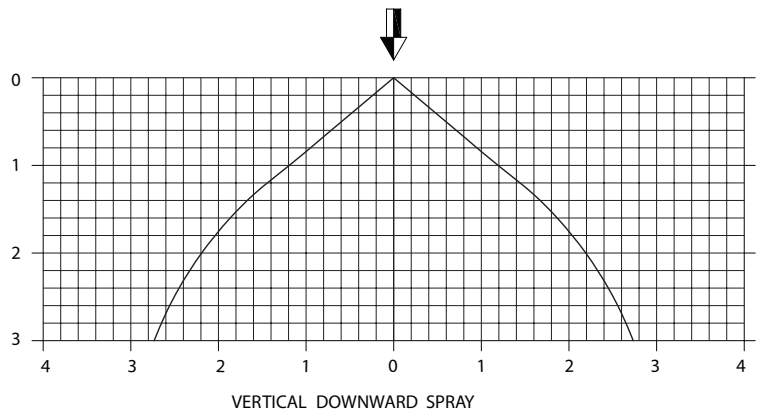
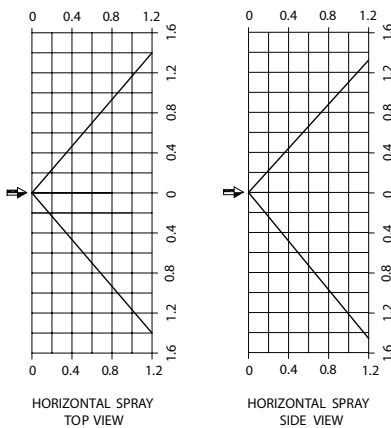

All Dimensions Are In Meters

# Medium Velocity Water Spray Nozzle

## Model: A, AS, B, BS & E

### SPRAY ANGLE 110°

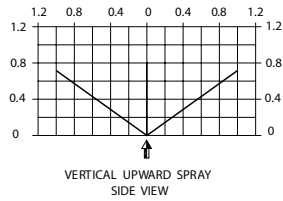
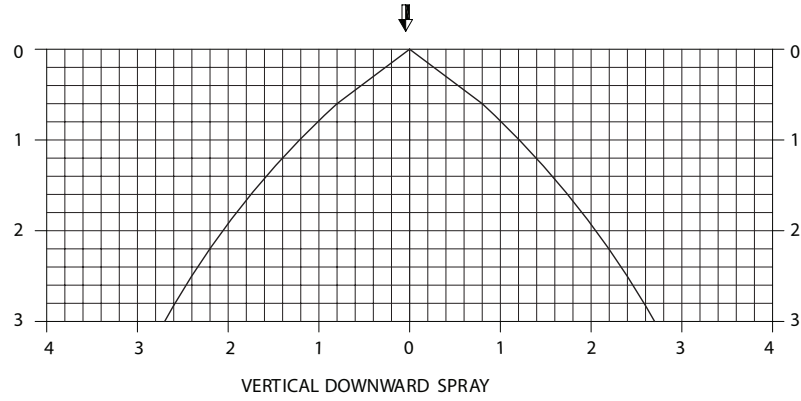
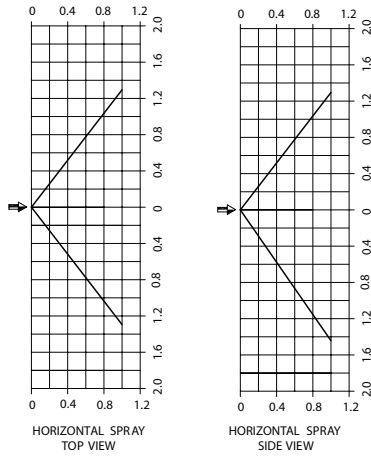

### SPRAY ANGLE 120°

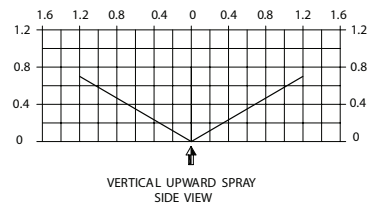
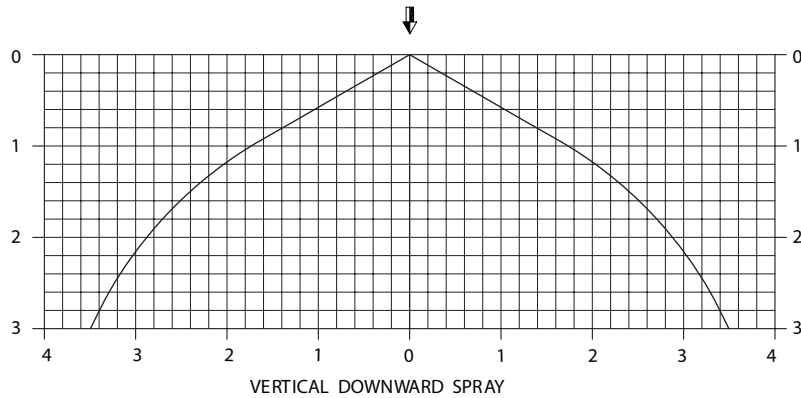
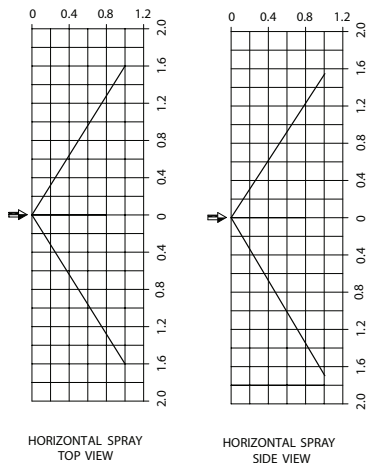

All Dimensions Are In Meters



Medium Velocity Water Spray Nozzle  
Model: A, AS, B, BS & E

SPRAY ANGLE 140°

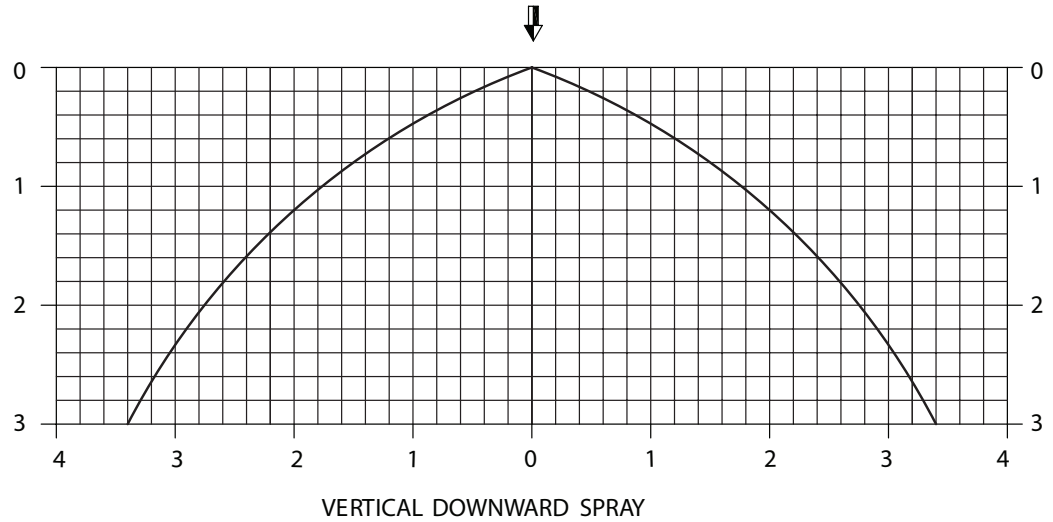
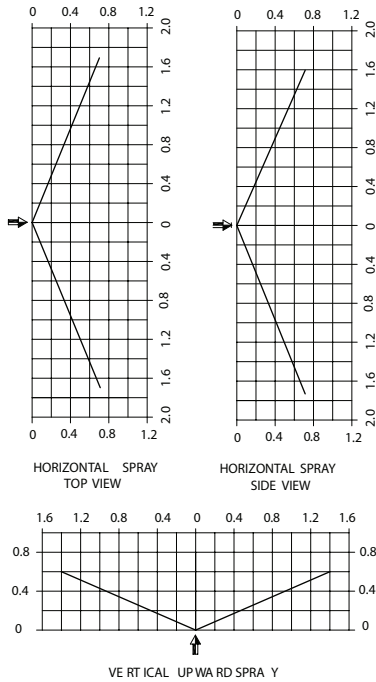

All Dimensions Are In Meters

Limited Warranty

Products supplied by Rapidrop (RD) are warranted against defects in material and workmanship for a period of Two (2) years from the date of shipment. RD's obligation under this warranty is limited to replace or repair the products or its parts, which are shown to RD's examination to be in a defective condition attributable to RD. No warranty is given for products or components which have been subject, to misuse, improper installation, corrosion, wear and tear improper storage, modification or repaired. If the defect attributable to RD cannot be rectified by repair or replacement, then RD may elect to refund the purchase price of the equipment in complete discharge of its obligation under this Limited Warranty.

IN NO EVENT SHALL RAPIDROP BE LIABLE IN CONTRACT, STRICT LIABILITY OR ANY OTHER LEGAL THEORY, FOR INCIDENTAL, IN-DIRECT, SPECIAL OR CONSEQUENTIAL DAMAGES, INCLUDING DAMAGES. FOR INJURY TO PERSON OR DEATH OR DAMAGE TO PROPERTY AND OR PENALTIES RESULTING FROM ANY PRODUCTS OR COMPONENT MANUFACTURED OR ASSEMBLED BY RD. THIS IS LIMITED WARRANTY ONLY. RD DISCLAIMS WITH RESPECT TO THE PRODUCTS ALL IMPLIED WARRANTIES OF MERCHANTABILITY AND ALL IMPLIED WARRANTIES OF FITNESS FOR A PARTICULAR PURPOSE. THERE IS NO WARRANTY OF ANY NATURE MADE BY RD BEYOND AS STATED ABOVE.

Notice :

The equipment presented in this bulletin is to be installed in accordance with the latest publication standards of NFPA or other similar organisations and also with the provision of government codes or ordinances wherever applicable. The information provided by us are to the best of our knowledge and belief, and are general guidelines only. Site handling and installation control is beyond our reach. Hence we give no guarantee for result and take no liability for damages, loss or penalties whatsoever, resulting from our suggestion, information, recommendation or damages due to our product. Product development is a continuous programme of RAPIDROP and hence the right to modify any specification without prior notice is reserved with the company.